

YuMi® creating an automated future together. You and me.



YuMi is the first truly collaborative dual armed robot, designed for a world in which humans and robots work together. It heralds a new era of robotic co-workers which are able to work side-by-side on the same tasks as humans with extreme accuracy while ensuring the safety of those around it.

Collaboration

YuMi is designed to meet the flexible and agile production needs required for small parts assembly in the electronics industry. It is also well suited to other small parts environments, including the manufacture of watches, toys and automotive components. All of this thanks to its dual-arms, flexible hands, universal parts feeding system, camera-based part location and state-of-the-art motion control.

Redefining safety

YuMi has a lightweight yet rigid magnesium skeleton covered with a floating plastic casing wrapped in soft padding, which absorbs the force of any unexpected impacts to a very high degree. YuMi has no pinch points so that sensitive ancillary parts cannot be crushed between two opposing surfaces as the axes open and close.

If YuMi senses an unexpected impact or change in its environment such as a collision with a coworker, it can pause its motion within milliseconds to prevent injury, and the motion can be restarted again as easily as pressing play on a remote control.

YuMi is very precise and fast, returning to the same point in space over and over again to within 0.02 mm accuracy and moving at a maximum velocity of 1,500 mm/sec. This ensures the safety of human co-workers on production lines and in fabricating cells.

Total solution concept

ABB also develops software and manufactures hardware, peripheral equipment, process equipment and modular manufacturing cells. This “total solution” concept is evident in YuMi’s breakthrough design.

Features

- The fifth-generation, integrated IRC5 controller with TrueMove and QuickMove™ motion control technology commands accuracy, speed, cycle-time, programmability and synchronization with external devices.
- I/O interfaces include Ethernet IP, Profibus, USB ports, DeviceNet™, communication port, emergency stop and air-to-hands. YuMi accepts a wide range of HMI devices including ABB’s teach pendant, industrial displays and commercially available tablets.
- The 100-240 volt power supply plugs into any power socket for worldwide versatility.

Benefits

- Can operate equally effectively side-by-side or face-to-face with human coworkers.
- Servo grippers (the “hands”) include options for built-in cameras.
- Real-time algorithms set a collision-free path for each arm customized for the required task.
- Padding protects coworkers in high-risk areas by absorbing force if contact is made.

Specification

Robot version	Reach (mm)	Payload (g)	Armload
IRB 14000-0.5/0.5	559	500	No armloads
Number of axes	14		
Protection	Std: IP30 and Clean Room		
Mounting	Table		
Controller	Integrated		
Integrated signal and power supply	24V Ethernet or 4 Signals		
Integrated air supply	1 per Arm on tool Flange (4 Bar)		
Integrated ethernet	One 100/10 Base-TX ethernet port/per arm		

Performance (according to ISO 9283)

IRB 14000-0.5/0.5	
0.5 kg picking cycle	
25* 300 * 25 mm	0.86s
Max TCP Velocity	1.5 m/s
Max TCP Acceleration	11 m/s*s
Acceleration time 0-1m/s	0.12s
Position repeatability	0.02 mm

Technical information

Physical	
Robot base	399 x 496 mm
Robot toes	399 x 134 mm
Weight	38 kg
Environment	
Ambient temperature for mechanical unit	
During operation	+5°C i (41°F) to +40°C (104°F)
During transportation and storage	-10°C (14°F) to +55°C (131°F)
Relative humidity	Max. 85%
Noise level	< 70 dB
Safety	PL b Cat B

Data and dimensions may be changed without notice.

Movement

Axis movement	Working range	Axis max. speed
Axis 1 arm rotation	-168.5° to +168.5°	180°/s
Axis 2 arm bend	-143.5° to +43.5°	180°/s
Axis 7 arm rotation	-168.5° to +168.5°	180°/s
Axis 3 arm bend	-123.5° to +80°	180°/s
Axis 4 wrist rotation	-290° to +290°	400°/s
Axis 5 wrist bend	-88° to +138°	400°/s
Axis 6 flange rotation	-229° to +229°	400°/s

Working range, front view

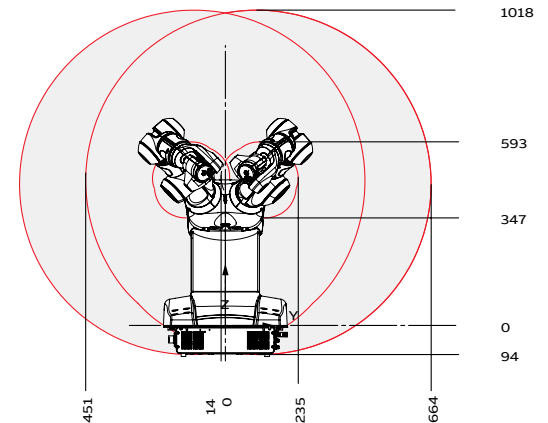

Working range, top view

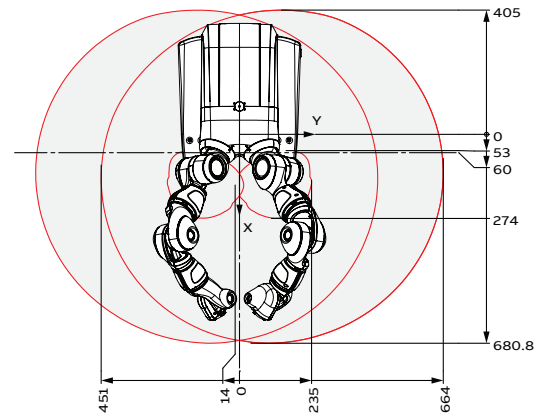

Working range, side view



abb.com/robotics



Australis Engineering
 Et i Zi z1 A fi" ## \$% ' # ' fi
 " i # ' ! ' f&
 ' () * + , . //
 fi \$ fD " fi " \$fi #12i 32"
 " fi " \$fi #12i 32"

We reserve the right to make technical changes or modify the contents of this document without prior notice. With regard to purchase orders, the agreed particulars shall prevail. ABB does not accept any responsibility whatsoever for potential errors or possible lack of information in this document.

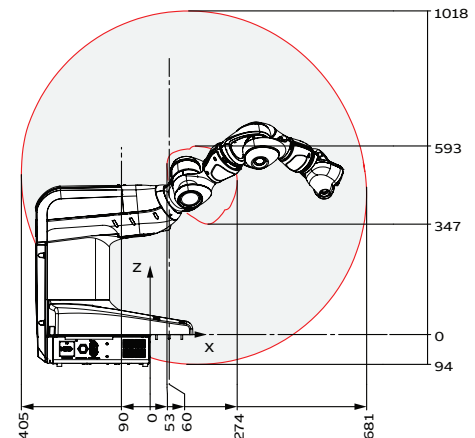
We reserve all rights in this document and in the subject matter and illustrations contained therein. Any reproduction, disclosure to third parties or utilization of its contents – in whole or in parts – is forbidden without prior written consent of ABB. Copyright © 2019 ABB. All rights reserved