



# DATASHEET

RG2



V1.0



**AUSTRALIS**  
ENGINEERING

**Australis Engineering Pty Ltd**  
25 Harley Crescent  
Condell Park, NSW, 2200 AUSTRALIA  
+61 2 9707 5888  
sales@australiseng.com.au  
australiseng.com.au

# 1 Datasheet

General Properties	Minimum	Typical	Maximum	Unit
Payload Force Fit 	- -	- -	2 4.4	[kg] [lb]
Payload Form Fit 	- -	- -	5 11	[kg] [lb]
Total stroke (adjustable)	0 0	- -	110 4.33	[mm] [inch]
Finger position resolution	- -	0.1 0.004	- -	[mm] [inch]
Repetition accuracy	- -	0.1 0.004	0.2 0.007	[mm] [inch]
Reversing backlash	0.1 0.004	- -	0.3 0.011	[mm] [inch]
Gripping force (adjustable)	3	-	40	[N]
Gripping force deviation		±25		%
Gripping speed*	38	-	127	[mm/s]
Gripping time**	0.06	-	0.21	[s]
Adjustable bracket tilting accuracy	-	< 1	-	°
Storage temperature	0 32	- -	60 140	[°C] [°F]
Motor	Integrated, electric BLDC			
IP Classification	IP54			
Dimensions	213 x 149 x 36 8.3 x 5.9 x 1.4			[mm] [inch]
Weight	0.78 1.72			[kg] [lb]

\*See table on the next page

\*\* based on 8mm total movement between fingers. The speed is linearly proportional to the force. For more details see speed table on next page.

Operating Conditions	Minimum	Typical	Maximum	Unit
Power supply	20	24	25	[V]
Current consumption	70	-	600*	[mA]
Operating temperature	5 41	- -	50 122	[°C] [°F]
Relative humidity (non-condensing)	0	-	95	[%]
Calculated MTBF (operating life)	30.000	-	-	[Hours]

\*Current spikes up to 3A (max 6mS) may occur during the release action.

### RG2 Gripping Speed Graph

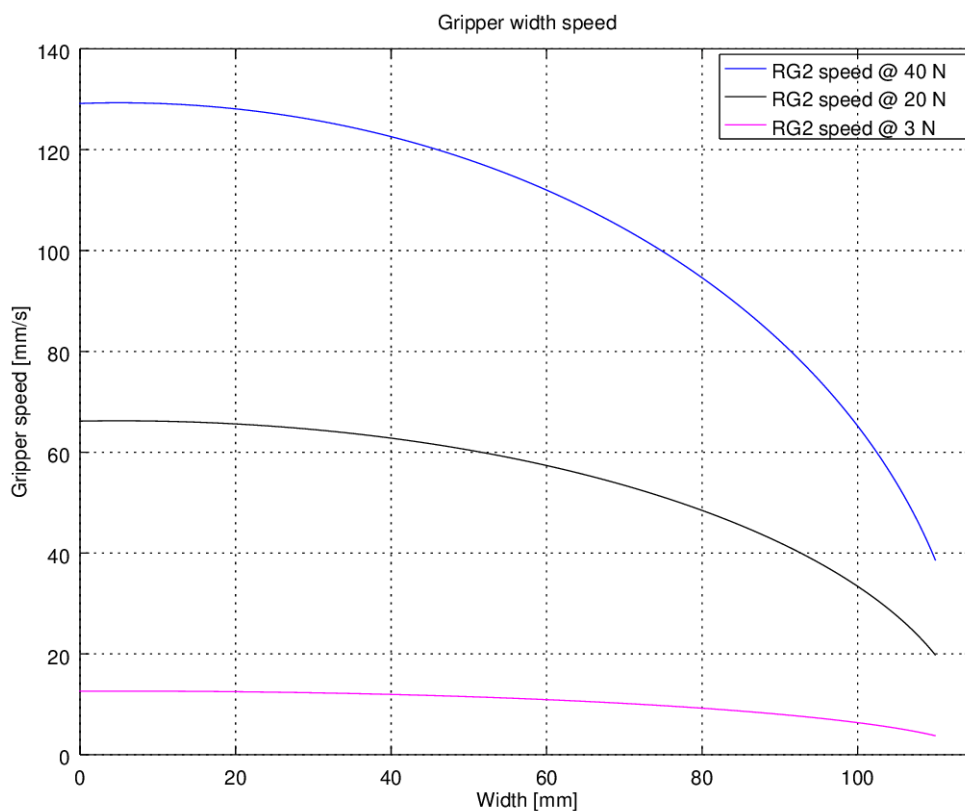

### RG2 Work Range

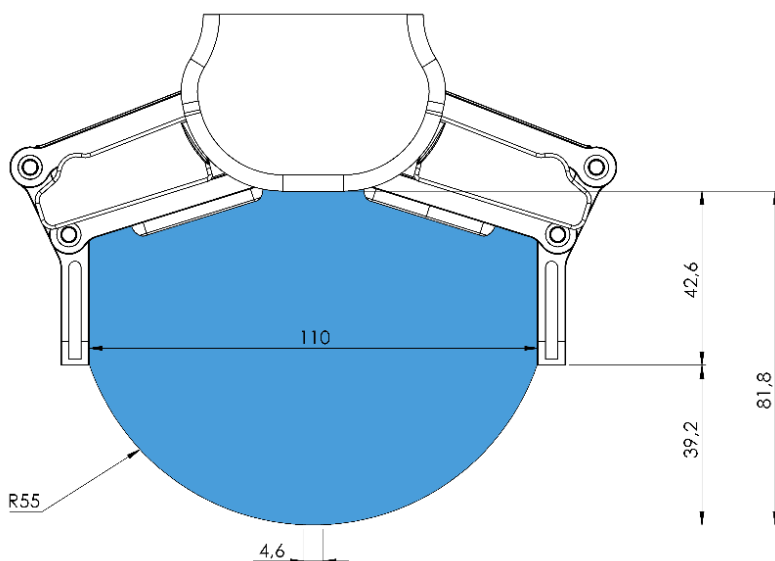

Gripping on long objects can unintentionally activate the Safety switches. The maximum workpiece height (calculated from the end of the fingertips) is dependent on the gripping width (w). For various width values the height (h) limit is given below:

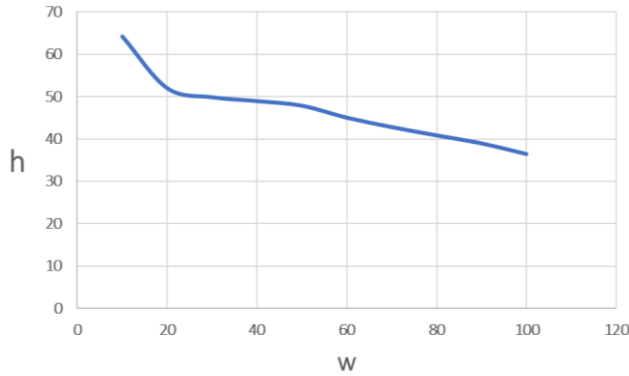

### Fingertips

The standard fingertips can be used for many different workpieces. If custom fingertips are required, they can be made to fit the Gripper's fingers according to the dimensions (mm) shown below:

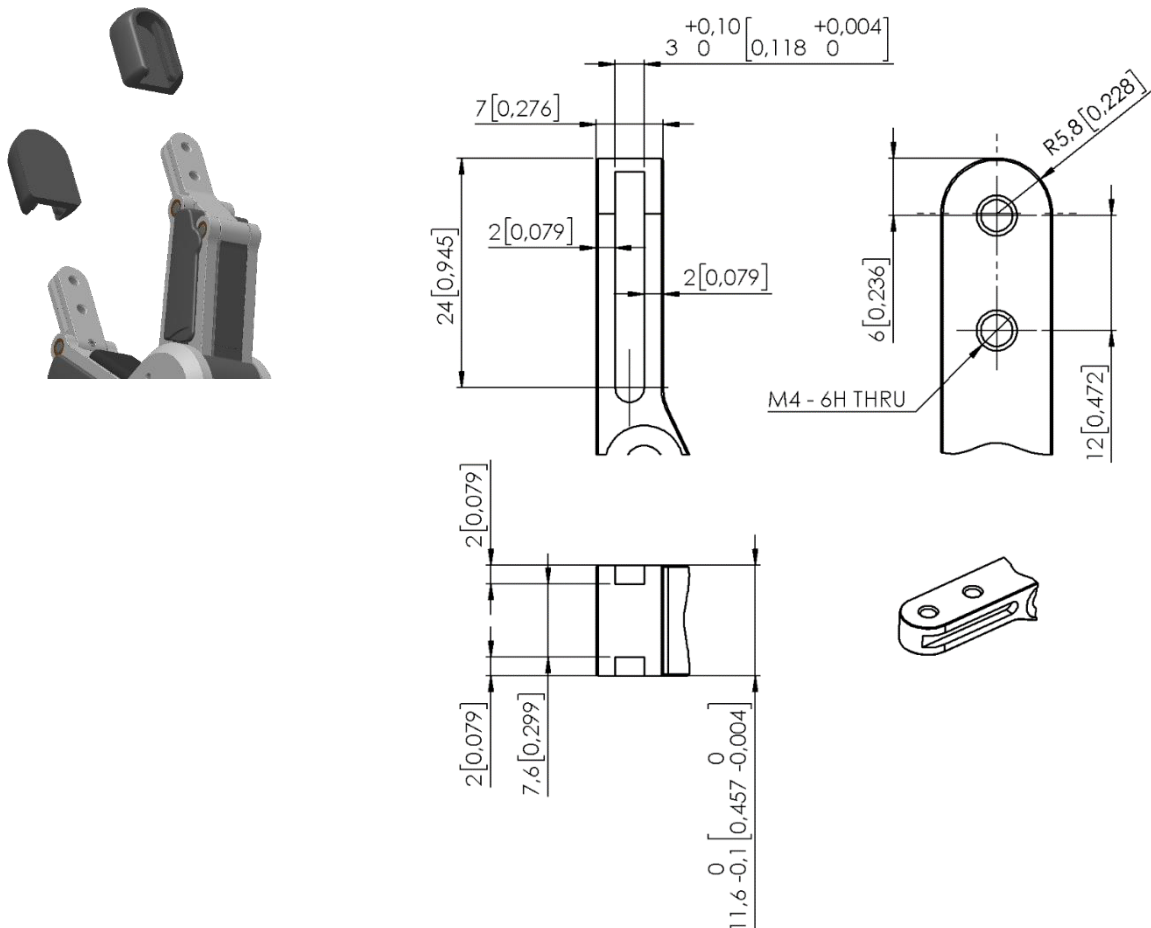

RG2

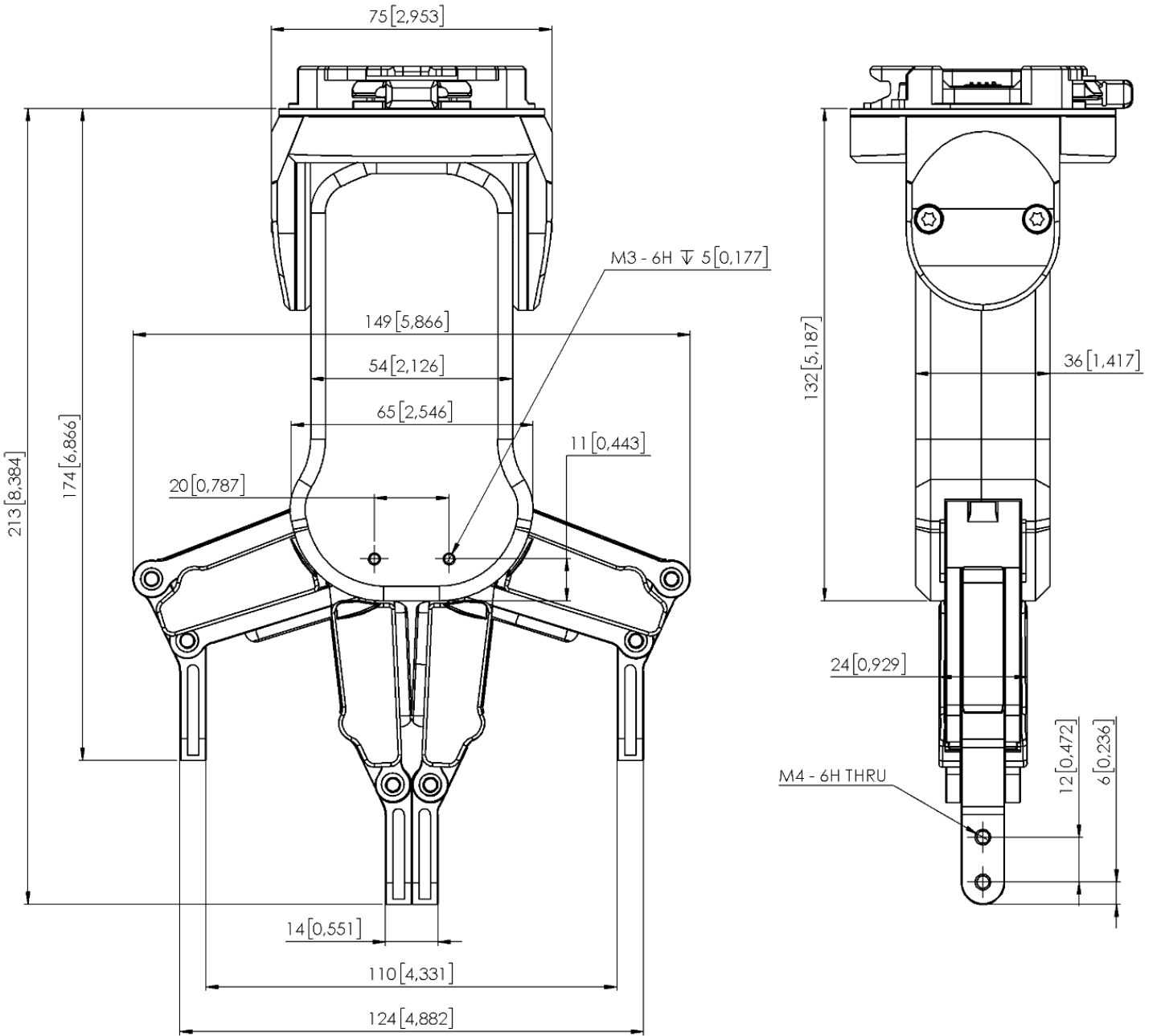

All dimensions are in mm and [inches].